

# AIRBENCH DESIGN STUDIO ARNE QUINZE



As an ultimate communication tool, an Airbench setting creates a landscape of human interaction. Available in variable shapes — crosses, rectangles or meanders — airbenches are multifunctional and modular, offering endless combination possibilities. Airbenches Small and Large move tortuously in public spaces. By accident people meet each other as they take place on the bench and immediately look into the opponents eyes. On the Airbench Cross, you're almost seated in front of each other. Staying silent is no longer an option as it burdens you with an unpleasant feeling. Verbal and social interaction, giving new energy and impulses, becomes the only standard in community life. On the Airbench Single and Double, people receive glimpses of each other and start communicating out of curiosity. People get interwoven by interaction. They are forced to sit in an open atmosphere and cocooning is very much a memory from the past. Due to the philosophy behind them, Airbenches are the ideal communication tools in public areas; musea, exhibitions, libraries, lounges, airports, waiting areas,...

**Custom color or sizes are available upon request.**

## AIRBENCH SINGLE 01

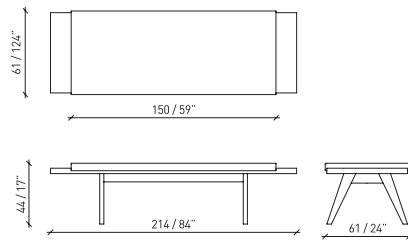

## AIRBENCH DOUBLE 01

\*BACKRESTS = WORK IN PROGRESS

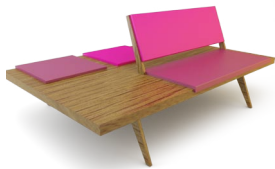
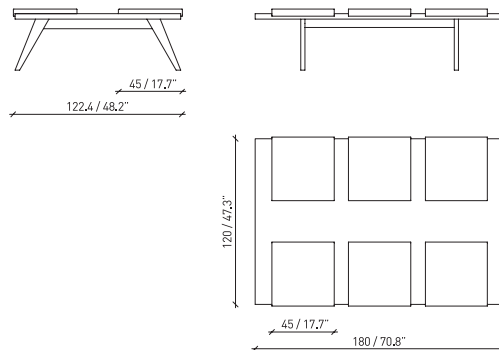

## AIRBENCH DOUBLE 02

\*BACKRESTS = WORK IN PROGRESS

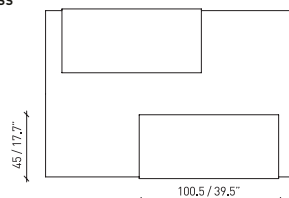

# AIRBENCH DESIGN STUDIO ARNE QUINZE



## AIRBENCH SMALL CROSS

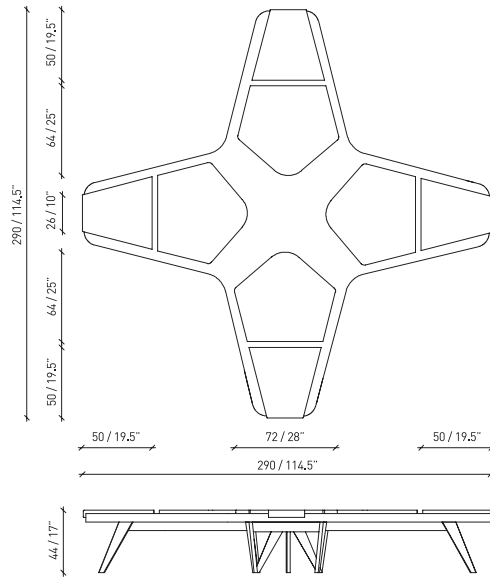

## AIRBENCH BIG CROSS

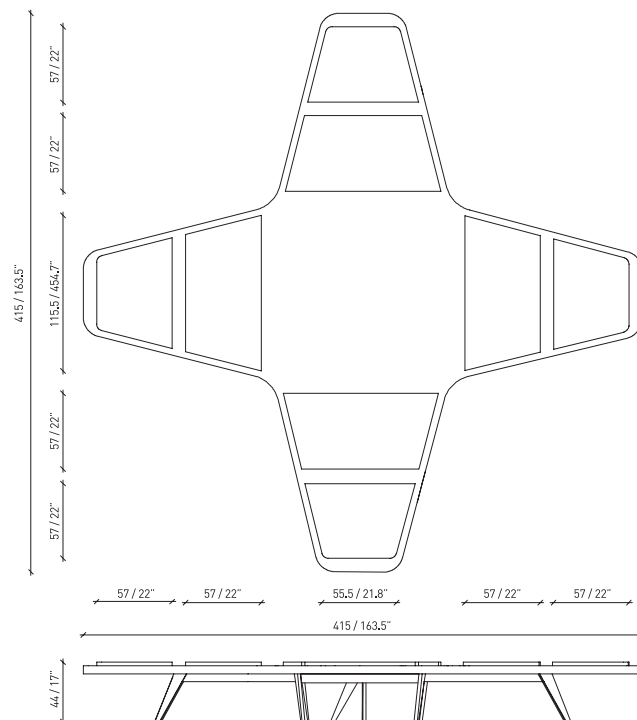

# AIRBENCH DESIGN STUDIO ARNE QUINZE



**AIRBENCH BOOMERANG S**

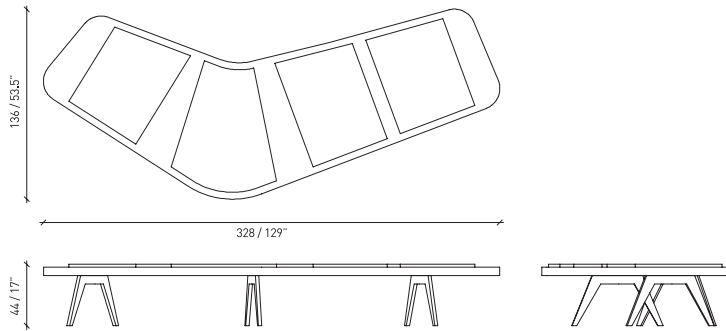

**AIRBENCH BOOMERANG L**

